

Tyga-Box Means Pack Direct To Dolly

Never Lift A Box Unless Its Empty

1. Place EMPTY
Tyga-Box On Tyga-Dolly
And Pack It

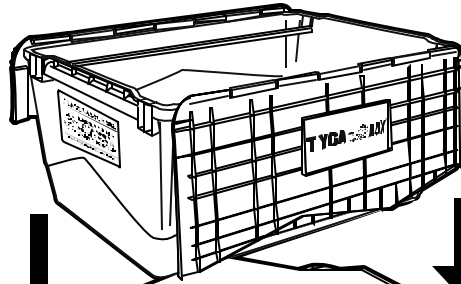

2. Flip Lids Shut

3. Place Next EMPTY
Tyga-Box On Stack
And Pack It

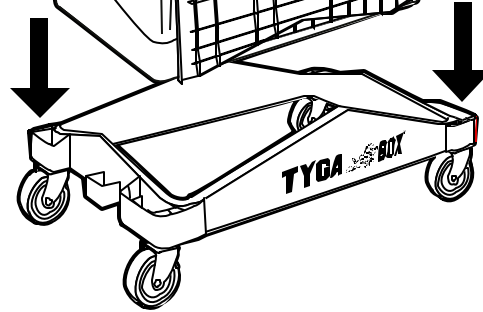

4. Continue To Build Stack
As You Pack

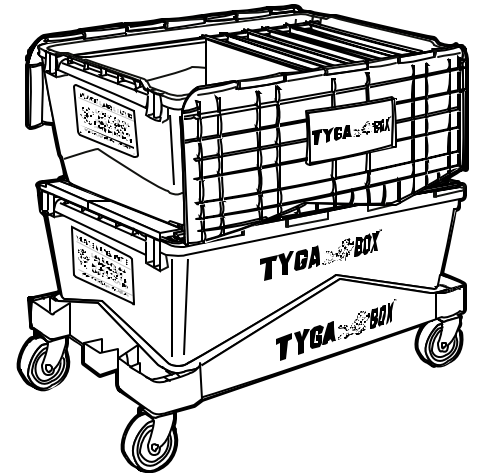

5. Maximum 5 High

6. With File Rails

Rails Are Stored On Top Of Lid
Press Down On Button 1 And Pull Rails Out
Then Place Rails In Slots Inside Box
Outer Slots For Legal / Inner Slots For Letter
RETURN RAILS TO LID AFTER USE

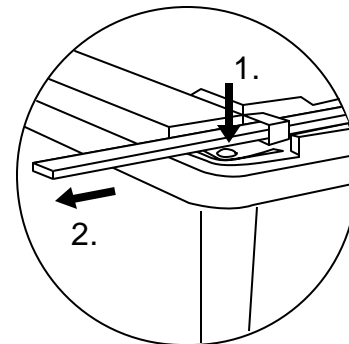

7. Without File Rails

Legal Size Files Along The Length
Letter Size Files 2 Across

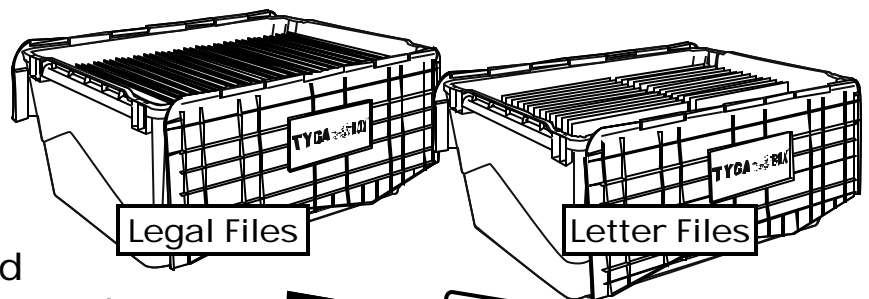

8. E-Z Peel Placard

Place Labels ONLY On The Placard
Your Mover Knows To Look For Them There
Please Remove Labels After Use

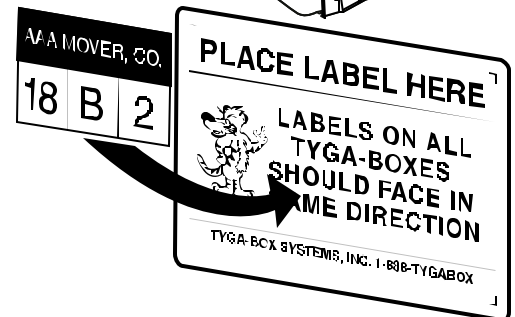

TYGA BOX
"The Leader In Innovative Moving Products"

1-888-TYGABOX ext 300 www.tygabox.com

Copyright 2002, Tyga-Box Systems, Inc.

Tyga-Box Unpack Direct From Dolly

Never Lift A Box Unless It's Empty

1. Open top box and remove contents while still on the stack.
2. Remove top box from stack after it's empty.
3. Repeat steps 1 & 2 until all boxes have been emptied and removed from stack -- Never Lift A Box Unless It's Empty.
4. Suggestion: For safety, load into file cabinet from bottom drawer up not from top drawer down.
5. Please Remove labels from Tyga-Boxes as you unpack.
6. Return file rails to their storage compartments on lid.
7. Return timely to avoid late return charges.
8. Ecological
 - . no trees cut down
 - . no waste created.

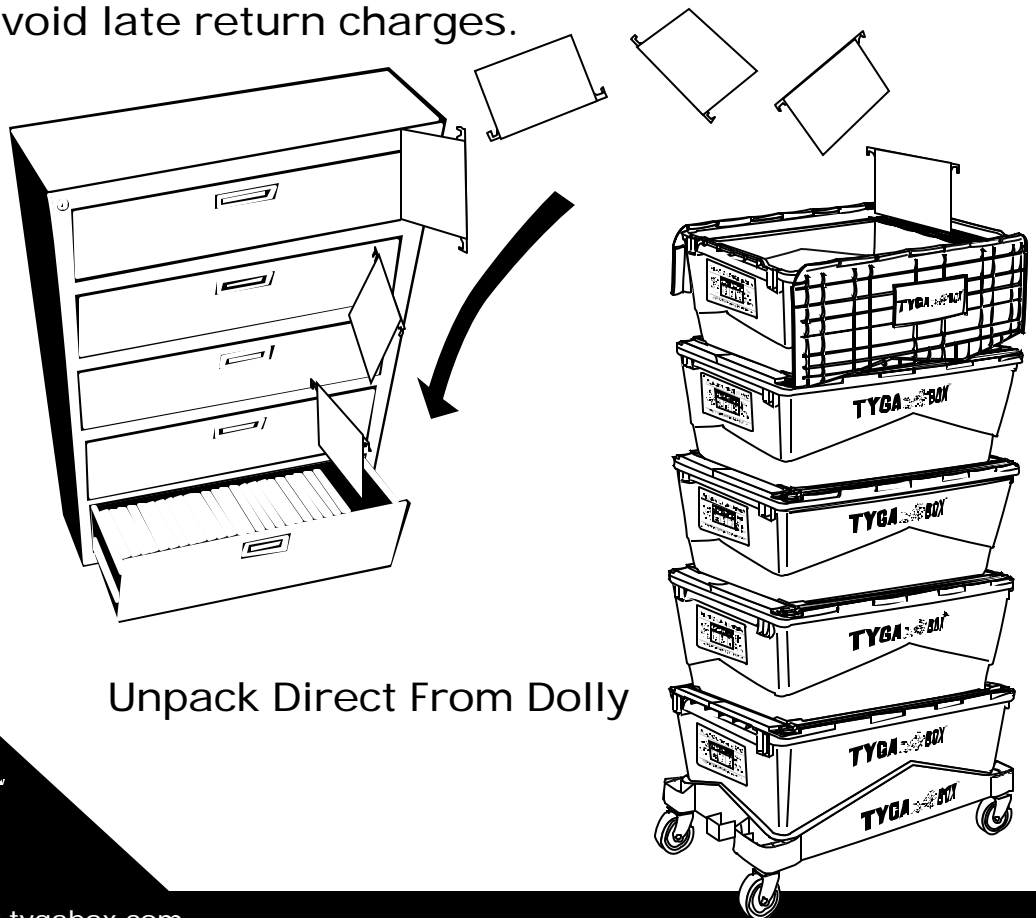

Unpack Direct From Dolly

TYGA BOX

"The Leader In Innovative Moving Products"

1-888-TYGABOX ext 300 www.tygabox.com

Copyright 2002, Tyga-Box Systems, Inc.